

Distance Sensor M7

Laser Sensor up to 10 kHz
measuring range 0,5 ... 400mm

Triangulation analog



- small sensor head due to separated electronic module
- independent from object surface: bright, dark
- very precise and fast measurement due to special analog module
- easy adjusting of measuring frequency and reaction time

• Measuring
• Controlling
• Monitoring

Type 2
Weight 240 g, cable length 2 m

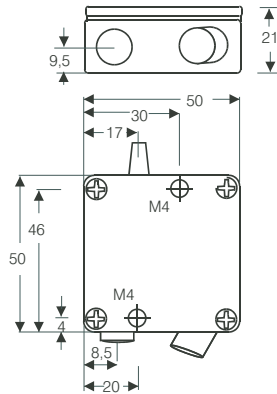

Type 3
Weight 400 g, cable length 2 m

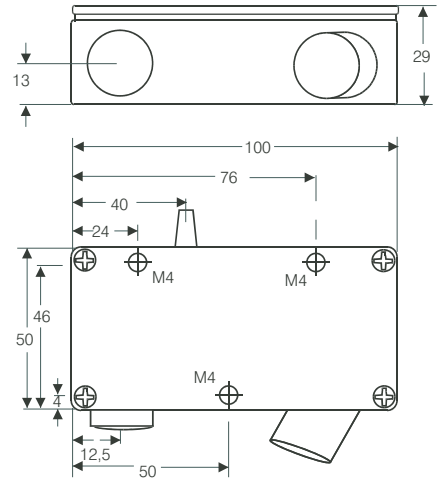

Type 1
Weight 250 g, cable length 2 m

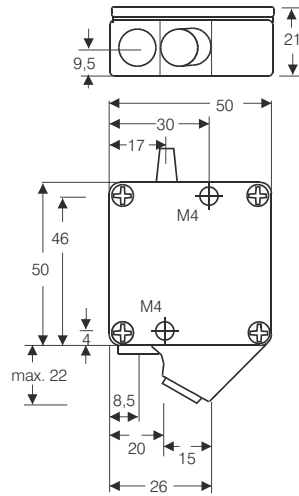

Type 5
Weight 200 g, cable length 2 m

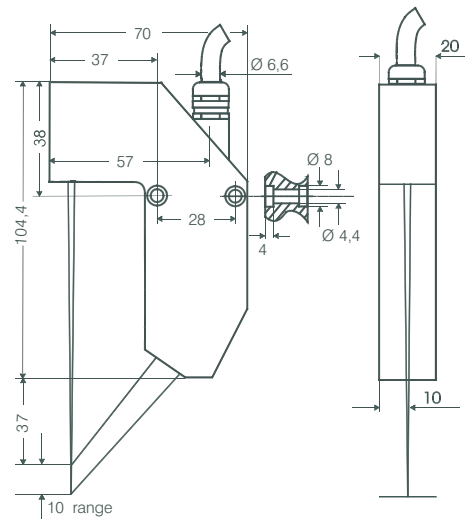

Type 4
Weight 850 g, cable length 2 m

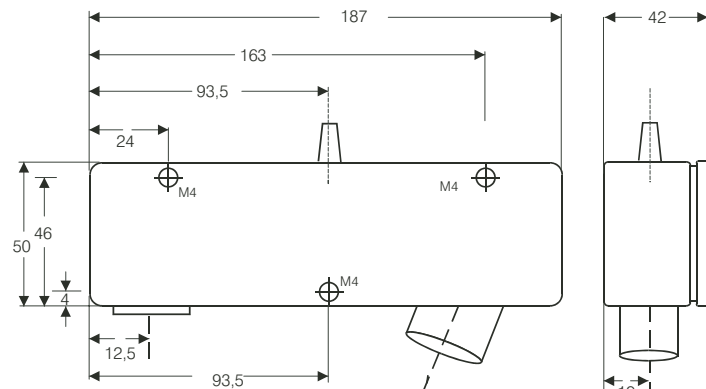

Laser Sensor M7

For all surfaces, matt black to high splendid, adjustable up to 10 kHz

Sensor	M7L/ 0,5	M7L/ 2	M7L/ 4	M7L/ 10	M7L/ 20	M7L/ 50	M7L/ 100	M7L/ 200	M7L/ 400	M7L/ 42/10
Casing type	1	2	2	2	2	3	3	3	4	5
Range [mm]	0,5	2	4	10	20	50	100	200	400	10
Range begin [mm]	23,75	23	22	40	55	95	170	240	480	37
Linearity* ± [µm]	1,0	4,0	8,0	20	40	100	200	400	700	20
Resolution* [µm]	0,2	0,4	1,0	5,0	9,0	30	60	200	600	3,0
Light spot diameter [mm]	0,1	0,2	0,3	0,6	0,9	1,5	1,5	2	4	0,2
Laser protection class	2	2	2	2	2	2	2	2	3R	2

Light source	Laser, 670 nm, red visible
Sampling frequency	54 kHz
Distance output	±10 V (optional 0 ... 10 V / 0 ... 5 V / ±5 V) RS 232 / 4 ... 20 mA (optional 0 ... 20 mA)
Impedance	approx. 0 Ohm (10 mA max.)
Analog outputs	Angle error with 30° of inclination (A-axis): approx. 0,5% on white surface
Reaction time	0,1 ... 67 ms
Bandwith	0,015 ... 10 kHz (-3 dB)
Temperature drift	0,02% of range / K
Intensity output	0 ... 10 V
Switching outputs	MIN +24 V / 10 mA when lower than MIN, LED yellow OK +24 V / 10 mA when higher than MIN and lower than MAX, LED green MAX +24 V / 10 mA when higher than MAX, LED orange
Error output	+24 V / 10 mA, LED red
Switching hysteresis	approx. 0,5% of range
Ambient light	20.000 Lux
Operation time	50.000 h for Laser diode
Isolation voltage	200 VDC, 0V against case
max. Vibration	5 g up to 1 kHz (sensor head, 20 g optional)
Operation temperature	0° ... +50°C
Storage temperature	-20° ... +70°C
Humidity	up to 90% RH
Protection class	Sensor: IP 64, Electronic system: IP 40
Supply	+24 VDC / 200 mA (10 ... 30 V)

* Measurement on object color white – bandwith 15 Hz

Delivery:

- Sensor with connection cable 2m
- Electronic unit
- 25 pin D-connector, soldering version
- Calibration report

Options:

- Special cable length
- Sensor head with integrated protection window
- Sensor head vibration resistant

Accessories:

- Thickness measuring system
- Increased laser capacity
- Protection casing
- Interference filter
- RS 232-Interface
- Extension cable 2m
- Power supply
- Plug-on power supply
- Digital display (display in mm)
- More accessories on request

Special types on request

Electronic unit M7-series



Standard delivery of M7, M72 and M74

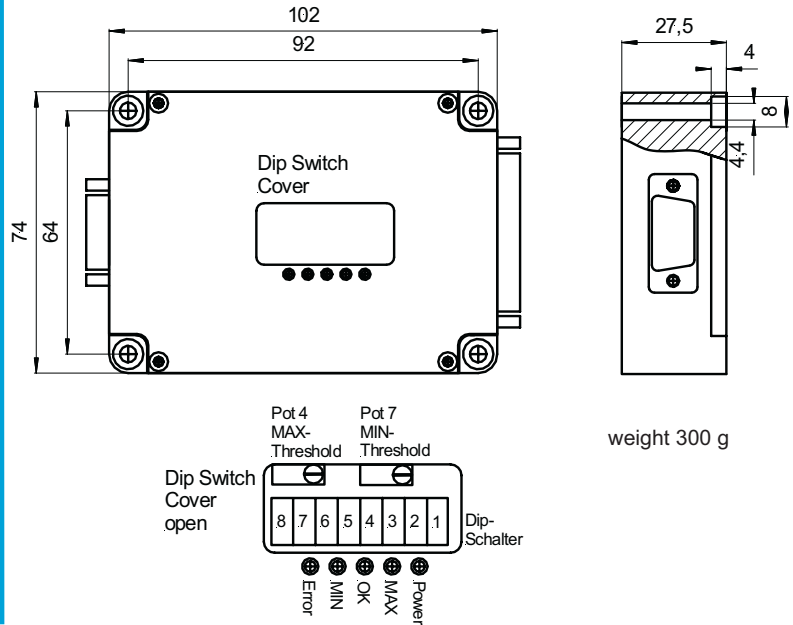

Pin assignment 25 pin SUB-D connector:

Pin	
1	Distance output ± 10 V
2	Error +24 V / 10 mA
3	Laser OFF, 0V
4	TXD
5	Range OK, +24 V / 10 mA
6	4 ... 20 mA
7	RXD
8	0V supply
14	Analog GND
16	MAX, +24 V / 10 mA
17	Input Sensor 2
18	RTS
19	MIN, +24 V / 10 mA
20	Intensity 0 ... 10 V
21	+24 V supply

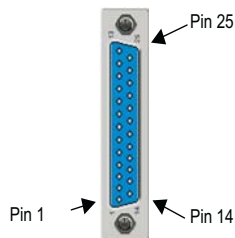

Dip switch settings:

SW1	Function
on	RS 232 Software Trigger with RXD
off	Stop with RTS

SW2	Function
on	RS 232 Baud rate = 38,4 kBaud
off	RS 232 Baud rate = 115,2 kBaud

SW3 unconnected

SW4	SW5	SW6	F/kHz	T/ms
on	on	on	10	0,1
off	on	on	7	0,14
on	off	on	4	0,25
off	off	on	1	1
on	on	off	0,25	4
off	on	off	0,1	10
on	off	off	0,025	40
off	off	off	0,015	67

SW7	SW8	Function
on	on	Normal-Laser off when I/O = GND
off	on	Trigger with I/O = GND
on	off	Sensor = Master
off	off	Sensor = Slave

Default setting 4 kHz