

## RadEye™ 3

### Large Area X-Ray Sensor

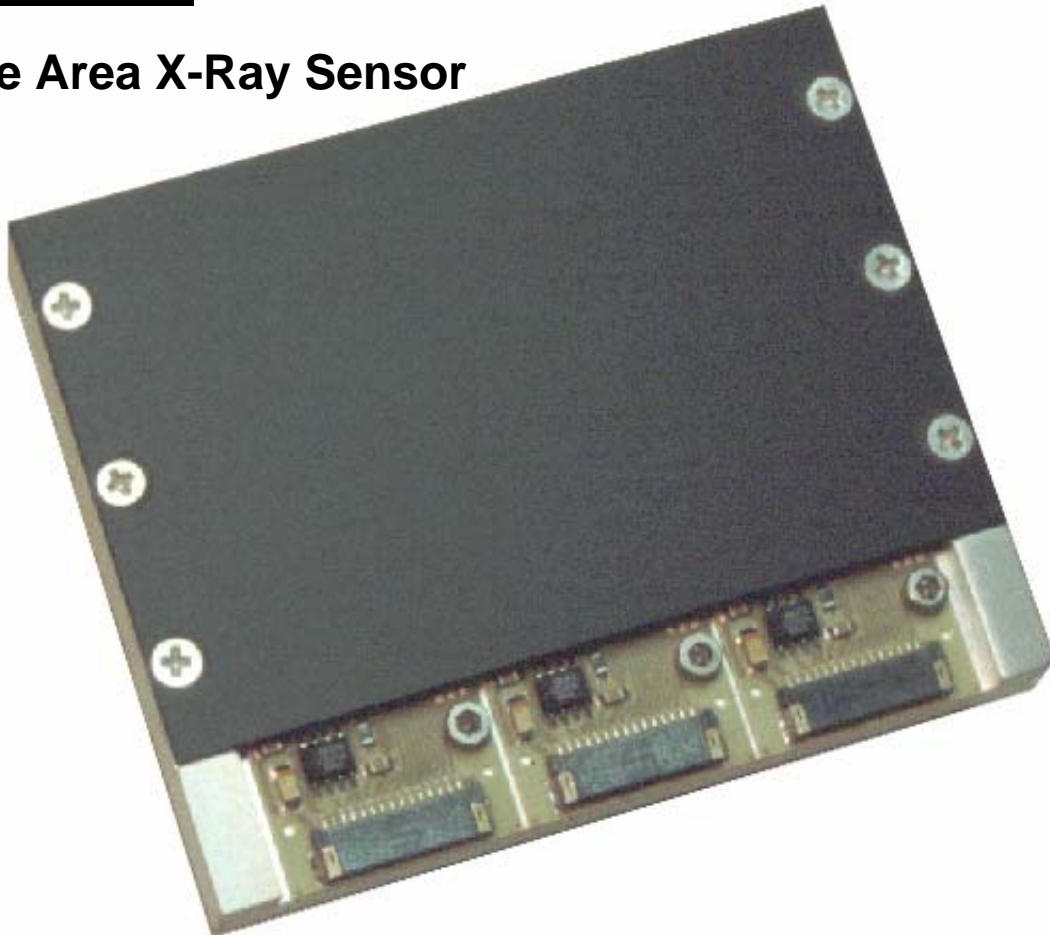

#### *Key Features:*

- Large 90 mm diagonal active area with 2:3 aspect ratio
- 10 lp/mm resolution
- Dynamic range >10,000:1
- Variable frame rate (0.01 – 4.5 Hz)
- Three parallel differential video outputs
- Fully integrated timing control
- Direct-coupled scintillator

The RadEye3 large-area image sensor continues the RadEye™ series' tradition of high performance and cost-effective value. The large 49.2 mm by 73.9 mm active area consists of a 1024 by 1536 matrix of silicon photodiodes on 48  $\mu\text{m}$  centers. Several timing modes allow for high flexibility in signal integration and readout. The RadEye3 is available in a standard configuration to detect x-rays and other energetic radiation in the 10 kV to 50 kV range, as well as in the EV model for x-ray energy up to 160 kV. Its uses cover a wide range of imaging applications from medical diagnostics to industrial inspection (NDT) and scientific imaging.

## Description:

The *RadEye3* large-area image sensor contains three individual *RadEye1* photodiode arrays along with their associated circuitry for scanning and readout. The three arrays operate in parallel and can be driven with a single set of control lines. They are aligned and mounted side-by-side on a common aluminum support base, resulting in a nearly seamless active area with a large 90 mm diagonal. The *RadEye3* module is packaged together with a scintillator in direct contact with the sensor, and a thin carbon-fiber window to protect the array. The EV model adds a fiber-optic faceplate (FOFP) between the scintillator and the sensor for added radiation resistance. Please note that the sensor enclosure is open towards the connector side and requires additional shielding against ambient light to operate the sensor.

The support and control functions for the *RadEye3* sensor are integrated on-chip to minimize the amount of external circuitry needed to run the imager. Five digital control inputs determine the integration and readout timing. In *continuous* mode (*START=high*) only an external pixel clock is required to run the device. In *frame* mode (*START=pulsed*) the frame rate and integration time can be controlled externally. Adjusting the *START* frequency controls the integration time or synchronizes the imager to an external trigger such as the firing of an x-ray source (see timing diagrams on next page). To assure proper initialization of the on-chip control circuitry, the sensor should always be powered up in frame mode.

Each frame consists of 1024 lines of pixel data. A line consists of 1536 pixels (512 pixels on each output) plus a blanking period. A *rising edge* on the *START* input triggers the beginning of each frame readout. *START* must return to a *low* level before the readout cycle ends. If *START* remains *high*, the next readout cycle begins immediately following the last line of the previous frame. The maximum *CLOCK* frequency is 2.5 MHz, which corresponds to a maximum frame rate of 4.5 frames per second (fps). In *continuous* mode, it is also possible to control the frame rate by adjusting the *CLOCK* frequency.

The *RadEye3* imager provides differential high-speed video signals from three parallel video outputs. The dark level on each output lies approximately 1.8 V below the reference voltage *VD*. The positive video outputs (*OUTS*) are pulsed above the dark level for each pixel, whereas the negative video outputs (*OUTR*) are pulsed below. At saturation, the two outputs will swing approximately 0.7 V above and below the dark level. The conversion gain for the differential signal (*OUTS* – *OUTR*) is 0.5  $\mu\text{V}$  per electron.

## Specifications:

Avg. dark current (at 23°C) ...4000 electrons/sec\*  
Read noise (rms, at 1 fps).....150 electrons  
Saturation.....2,800,000 electrons  
Dynamic range .....85 dB (>14 bits)  
Frame rate.....0.01 to 4.5 fps  
Max. data rate (each output) .....2.5 MHz  
Conversion gain (typ).....0.5  $\mu\text{V}$ /electron  
Supply voltage (*VDD*).....5 V (+0.1/-0.5 V)  
Supply current.....3 x 20 mA (typ)  
Reference voltage (*VD*) .....3.8 V (+0.5/-1.3 V)  
Analog output + .....2 V (dark) to 2.7 V (sat)  
Analog output – .....2 V (dark) to 1.3 V (sat)  
Digital “low” voltage.....0.5 V max.  
Digital “high” voltage .....4.5 V min.  
Operating temperature.....0 to 50 °C  
Storage temperature .....-25 to +85 °C

\* dark current doubles approx. every 8°C

## Connector Pinout:

Pin	Type	Signal	Description
1		VDD	Power (+5V)
2		GND	Ground
3	A	OUTS	Video Output +
4	A	OUTR	Video Output -
5		GND	Ground
6	A	VD	Reference In
7		GND	Ground
8	D	SCAN	Scan Mode In
9	D	START	Frame Start In
10	D	CLOCK	Master Clock In
11	D	BIN	Binning Select In
12	D	NDR	NDR Select In
13	D	FRAME	Frame Sync Out
14	D	LINE	Line Sync Out
15		GND	Ground

Type: A = Analog Signal D = Digital Signal

## Timing Diagrams:

### 1. Continuous Mode (START is always high)

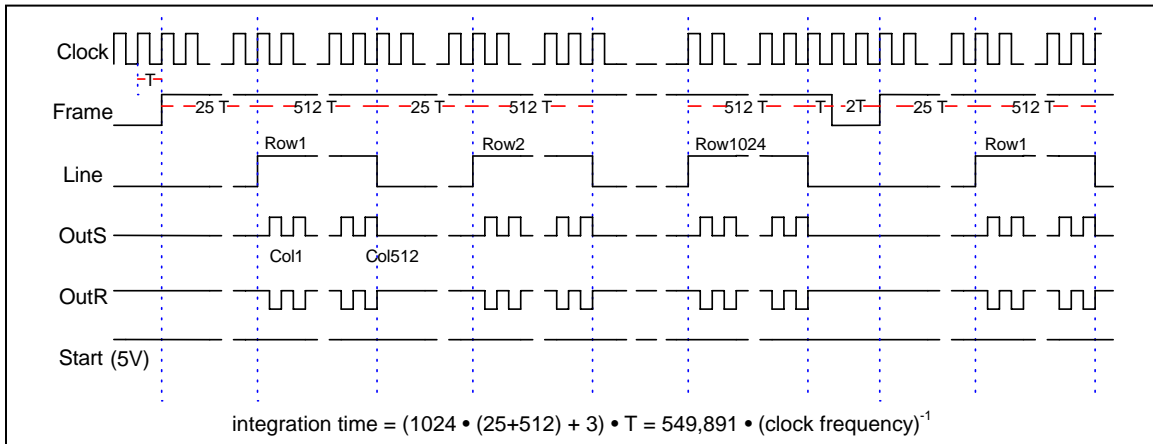

### 2. Frame Mode (START is pulsed)

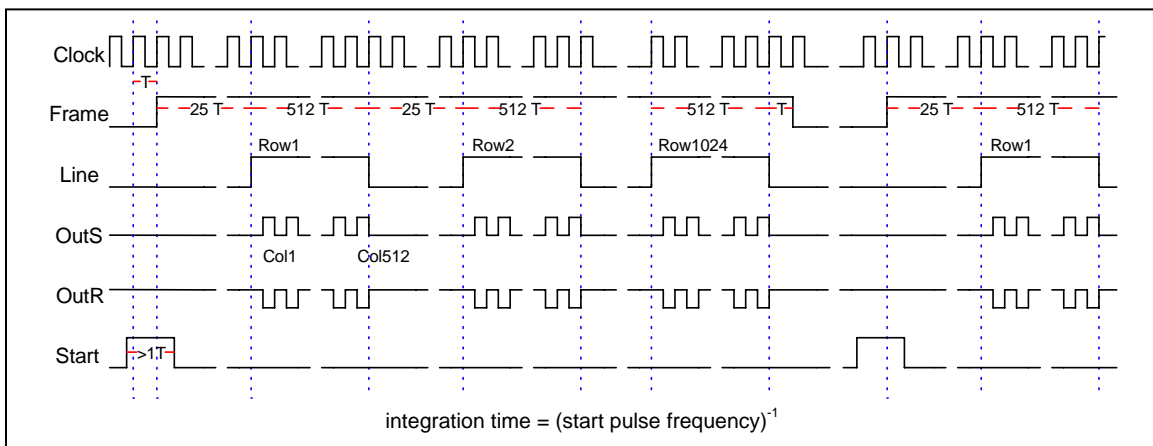

## Additional Timing Modes:

The BIN and SCAN inputs offer additional control over the readout functions. The BIN input, when *high*, causes the readout to skip every other row and column. This shortens the readout time and raises the maximum frame rate to 17.4 fps. A high level on the SCAN input puts the sensor into a rapid-readout mode in which only the first six pixels of each row segment are read. This feature can be used to rapidly reset the dark signal prior to an exposure.

The *RadEye3* also features a non-destructive readout (NDR) mode that is activated by setting the NDR input to a *high* level. In this mode, the voltage at each pixel is sampled without resetting the photodiode. This feature can be used to monitor the exposure level in the device, or to implement a low-noise readout mode by reading out and subtracting two images before and after an exposure. Both analog outputs carry the same signal when NDR is turned on. There is a slight increase in fixed-pattern noise when the NDR mode is activated, which can be compensated for by performing the appropriate offset correction in software. Please refer to *Rad-icon Application Note AN04* for more information on the *RadEye* sensor timing and using the NDR mode.

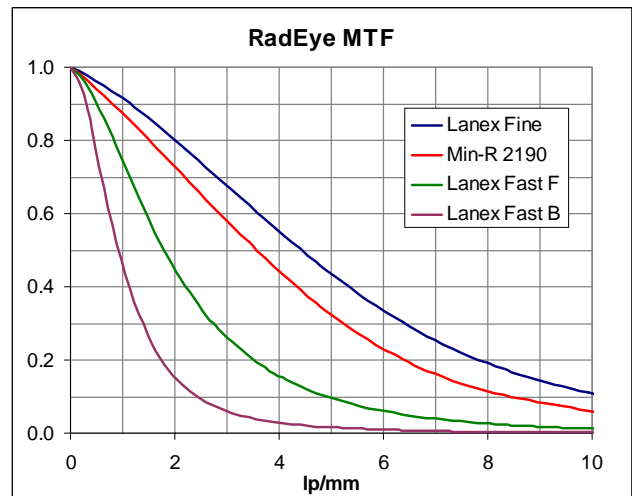

Detector resolution with various scintillators.

## Mechanical Dimensions:

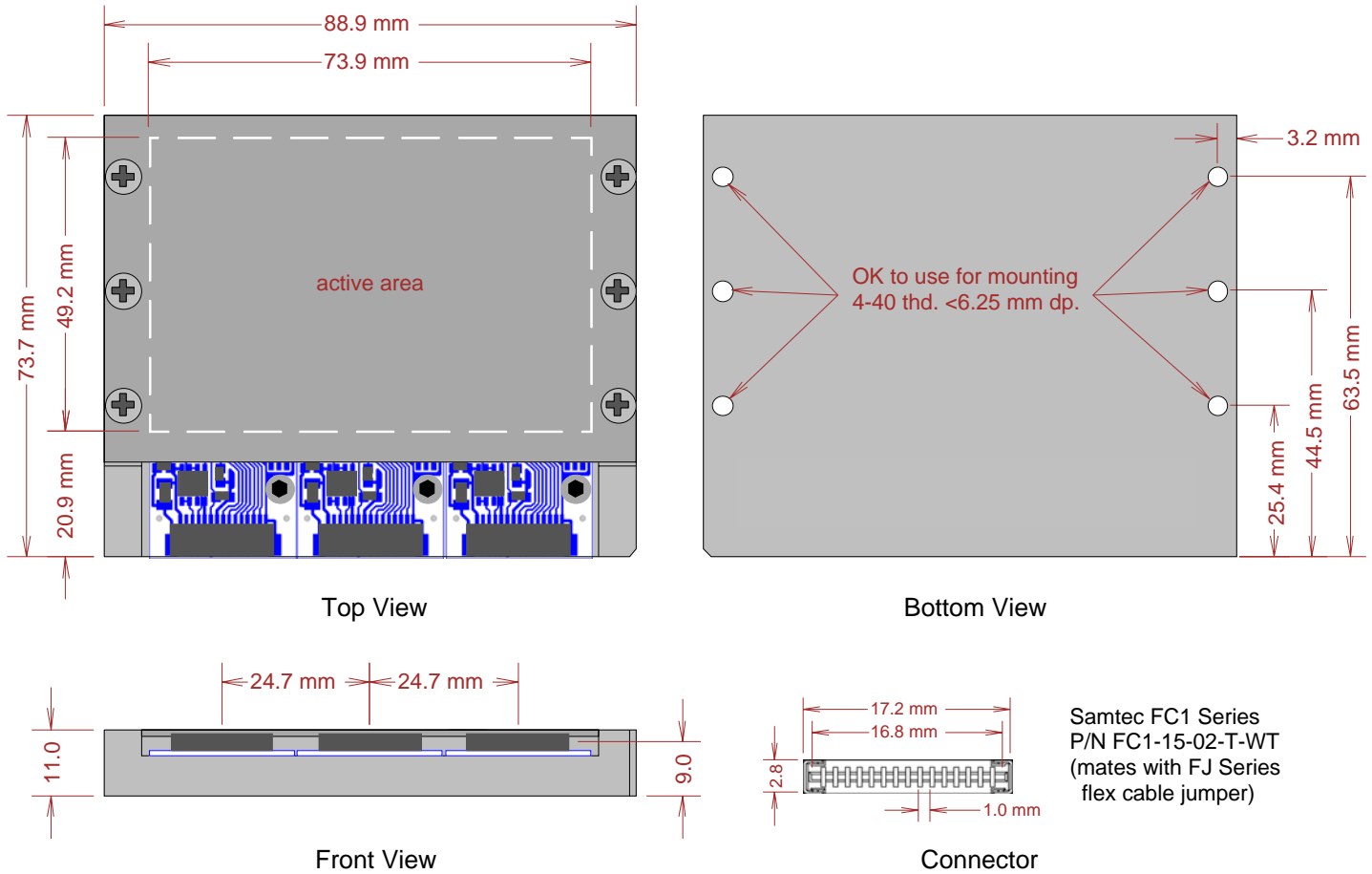

Samtec FC1 Series  
P/N FC1-15-02-T-WT  
(mates with FJ Series  
flex cable jumper)

The *RadEye3* module contains three individual *RadEye1* sensors that are mounted side-by-side and aligned to each other with sub-pixel accuracy. Two small gaps, each approximately two pixels wide, separate the three sections of the active area. Three identical 15-pin flex cable connectors (Samtec P/N FC1-15-02-T-WT) provide power and signal connections to the sensors. Except for the output signals from each sensor (pins 3, 4, 13 and 14) all pins can be connected in parallel.

Depending on the application, it may be possible to ignore the gaps between the three image sections and simply merge the images together. Another option is to interpolate the missing information across the gaps. Please refer to *Rad-Icon Application Note AN03* for more detailed information regarding this topic.

## Ordering Information:

Rad-Icon P/N	Description
RE1028	RadEye3 (low dose, 10-50 kV)
RE1060	RadEye3 EV (high dose, 10-160 kV)
-01	Premium Grade <sup>1</sup> , Min-R 2190 Scintillator
-02	Standard Grade <sup>2</sup> , Min-R 2190 Scintillator
-03	Premium Grade, Lanex Fine Scintillator
-04	Standard Grade, Lanex Fine Scintillator

<sup>1</sup> up to 1 line defect    <sup>2</sup> up to five line defects

The standard *RadEye3* module is packaged with a Gd<sub>2</sub>O<sub>2</sub>S scintillator (Kodak Min-R 2190 or Lanex Fine) and a 1 mm thick graphite window. Other scintillator and window options may be available on request.